

From Nixalite®

Bird Netting Applicator Platform for Vineyards & Row Crops



Speed the seasonal installation and removal of protective Bare Hand bird netting with a Applicator Platform from Nixalite. Heavy duty steel platform with a double ring boom mounts to a standard 3-point hitch.

The Applicator Platform is designed to make the application or removal of the Bare Hand Vineyard and Row Crop bird netting (or similar bag netting) quick and efficient.

The Applicator Platform consists of a heavy duty steel deck with containment rails, 3-point hitch receiver and an adjustable, double-hoop boom that guides the netting up and over the rows of crops.

The Applicator Platform makes netting installation and removal fast enough for large commercial fields while it is affordable enough for smaller farms and vineyards.



Using the Applicator Platform, a 3 man crew can cover large areas quickly and efficiently.

While the Applicator Platform is not required to apply the Bare Hand Bird Netting, it does make the application and removal more efficient. If you do not have a tractor or utility vehicle with a 3 point hitch, the netting can still be installed by other means. Contact Nixalite for information.

ALWAYS read the product instructions before use!!!



Nixalite® of America Inc.
1025 16th Avenue East Moline, IL. 61244
Experts In Architectural Bird Control Since 1950

Phone: 800.624.1189 or 309.755.8771
Fax: 800.624.1196 or 309.755.0077
Email: birdcontrol@nixalite.com
Web: www.nixalite.com

Where the World Shops for Humane Bird and Animal Control.



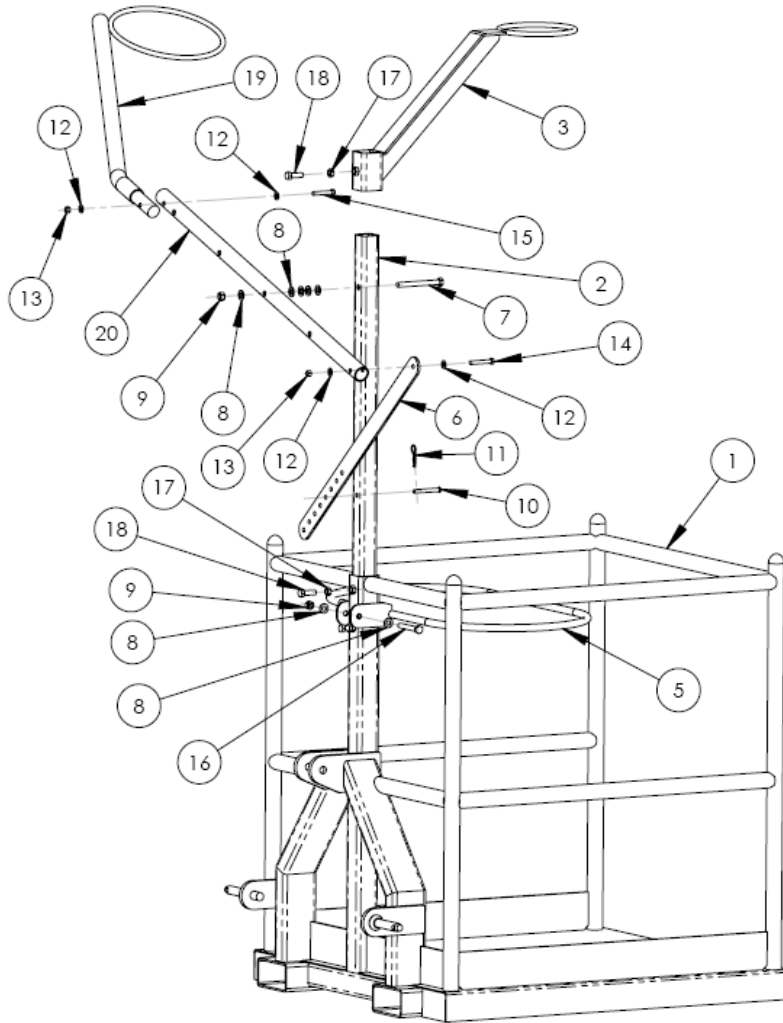

ITEM NO.	PART NUMBER	DESCRIPTION	QTY
1	11414	NETTING PLATFORM	1
2	11277	TUBE, NET MAST INNER	1
3	11282	UPPER BOOM RING	1
4	11336	PIN, CAT1 3-POINT LIFT	2
5	11343	FRAME, BAG MOUNT	1
6	11349	BOOM ADJUSTMENT BAR	1
7	10760	BOLT, 1/2-13 X 5 GR8 ZY	1
8	10062	WASHER- 1/2 SAE GR8 ZY	8
9	10395	NUT - 1/2-13 GR8 ZY	2
10	11615	CLEVIS PIN, 3/8 X 3	1
11	11614	HAIRPIN COTTER, 1/8	1
12	10110	WASHER, 3/8 SAE GR8 ZY	4
13	10947	NUT, 3/8-16 SLTL GR8 ZY	2
14	10690	BOLT, 3/8-16 X 2.50 GR8 ZY	1
15	11616	BOLT, 3/8-16 X 2.25 GR8 ZY	1
16	11617	BOLT - 1/2-13 X 3.75 GR8 ZY	1
17	11125	JAM NUT - 1/2-13 GR8 ZY	3
18	10394	BOLT - 1/2-13 X 1.50 GR8 ZY	3
19	11348	NETTING BOOM	1
20	11411	TUBE, ADJUSTABLE	1



Nixalite® of America Inc.
 1025 16th Avenue East Moline, IL. 61244
 Experts In Architectural Bird Control Since 1950

Phone: 800.624.1189 or 309.755.8771
Fax: 800.624.1196 or 309.755.0077
Email: birdcontrol@nixalite.com
Web: www.nixalite.com



Where the World Shops for Humane Bird and Animal Control.